



USER MANUAL

**Porsche OMP -14 / Porsche OMP -24
MPPT Solar Inverter**

1.4KVA/2.4KVA

Table of Contents

1. Introduction	1
2. Important Safety Warning (SAVE THESE INSTRUCTIONS)	1
3. Product Overview	3
4. Installation	3
5. Operation	6
6. Trouble Shooting	15
7. Specifications	16

1. Introduction

Thank you for purchasing this solar inverter. This simple solar inverter is designed to power your home appliances or precious 3C electronics. It also can handle motor-type loads with high surge power such as vacuums, small freezers, or drills. With built-in MPPT solar charger, it can convert solar power to battery power and provide continuous power to connected equipment during night time.

This manual is for qualified personnel. The tasks described in this manual may be performed by qualified personnel only.

2. Important Safety Warning (SAVE THESE INSTRUCTIONS)

Before using the inverter, please read all instructions and cautionary markings on the unit, this manual and the batteries.

Conventions used:

WARNING! Warnings identify conditions or practices that could result in personal injury;

CAUTION! Caution identify conditions or practices that could result in damaged to the unit or other equipment connected.

General Precaution-

CAUTION! The unit is designed for indoor use. Do not expose this unit to rain, snow or liquids of any type.

CAUTION! To reduce risk of injury, only use qualified batteries from qualified distributors or manufacturers. Any unqualified batteries may cause damage and injury. Do NOT use old or overdue batteries. Please check the battery type and date code before installation to avoid damage and injury.

CAUTION! Authorized service personnel should reduce the risk of electrical shock by disconnecting AC, DC and battery power from the inverter before attempting any maintenance or cleaning or working on any circuits connected to the inverter. Turning off controls will not reduce this risk. Internal capacitors can remain charged for 5 minutes after disconnecting all sources of power.

CAUTION! Do not disassemble this inverter yourself. It contains no user-serviceable parts. Attempt to service this inverter yourself may cause a risk of electrical shock or fire and will void the warranty from the Manufacturer.

CAUTION! To avoid a risk of fire and electric shock, make sure that existing wiring is in good condition and that the wire is not undersized. Do not operate the Inverter with damaged or substandard wiring.

CAUTION! To reduce risk of fire hazard, do not cover or obstruct the cooling fan.

CAUTION! Do not operate the inverter if it has received a sharp blow, been dropped, or otherwise damaged in any way. If the inverter is damaged, called for an RMA (Return Material Authorization).

WARNING: There are no user-replaceable parts inside of the inverter. Do not attempt to service the unit yourself.

WARNING! It's very important for system safety and efficient operation to use appropriate external battery cable. To reduce risk of injury, external battery cables should be UL certified and rated for 105°C or higher. And do not use copper cables less than 6AWG or 10AWG*2.

CAUTION! Do not disassemble the inverter. Contact with the qualified service center when service or repair is required.

WARNING! Provide ventilation to outdoors from the battery compartment. The battery enclosure should be designed to prevent accumulation and concentration of hydrogen gas at the top of the compartment.

CAUTION! Use insulated tools to reduce the chance of short-circuit when installing or working with the inverter, the batteries, or other equipments attached to this unit.

CAUTION! For battery installation and maintenance, read the battery manufacturer's installation and maintenance instructions prior to operating.

Personnel Precaution -

CAUTION! Careful to reduce the risk of dropping a metal tool on the batteries. It could spark or short circuit the batteries and could cause an explosion.

CAUTION! Remove personal metal items such as rings, bracelets, necklaces, and watches when working with batteries. Batteries can produce a short circuit current high enough to make metal melt, and could cause severe burns.

CAUTION! Avoid touching eyes while working near batteries.

CAUTION! Have plenty of fresh water and soap nearby in case battery acid contacts skin, clothing, or eyes.
CAUTION! NEVER smoke or allow a spark or flame in vicinity of a battery.
CAUTION! If a remote or automatic generator start system is used, disable the automatic starting circuit or disconnect the generator to prevent accident during servicing.

3. Product Overview

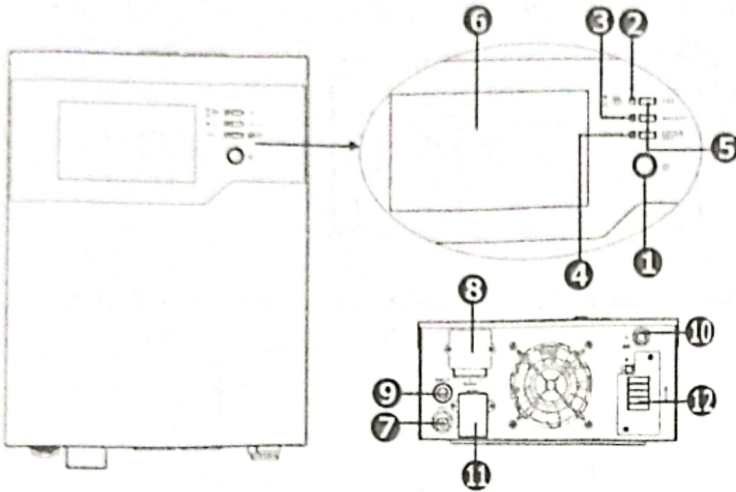

1. Power switch
2. Status indicator
3. Charging indicator
4. Fault indicator
5. Function buttons
(Please see the Operation section for the details)
6. LCD display
7. AC input
8. AC output terminals
9. Input circuit breaker
10. External battery connectors
11. Solar connector
12. DC fuse

4. Installation

NOTE: Before installation, please inspect the unit. Be sure that nothing inside the package is damaged.

Mounting the unit

The unit **ONLY** can be mounted vertically to a wall surface.

Please follow below steps:

1. Turn off the unit before mounting.
2. Select an appropriate mounting location. Mark four mounted ends as shown in chart.
3. Drill four marks by screws.
4. Mount the unit by positioning the key-hole slots over the mounting screws.

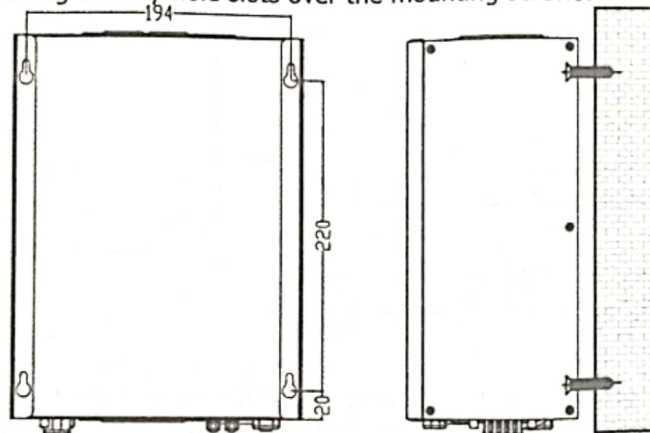

Connect to Utility and Charge

Plug in the AC input cord to the wall outlet. The unit will automatically charge the connected external battery even though the unit is off.

Connect to External Battery

Step 1- Install a DC Breaker in a positive battery line. The rating of the DC Breaker must be according to the inverter's battery current (100 Amp). Keep the DC breaker off.

Step 2 - Remove insulation sleeve 18 mm for positive and negative conductors.

Step 3- Connect battery cables to the external batteries.

Note: For the user operation safety, we strongly recommend that you should use tapes to isolate the battery terminals before you start to operate the unit.

1) **Single battery connection:** When using a single battery, its voltage must be equal to the Nominal DC Voltage of the unit

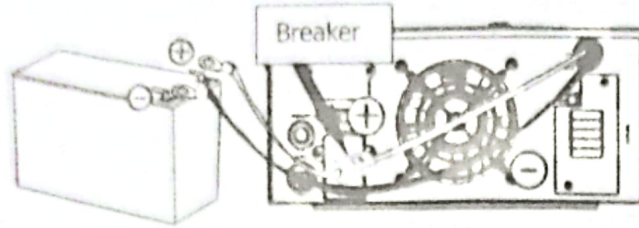

2) **Multiple batteries in series connection(Refer to Fig. 3):** All batteries must be equal in voltage and amp hour capacity. The sum of their voltages must be equal to the nominal DC Voltage of the unit.

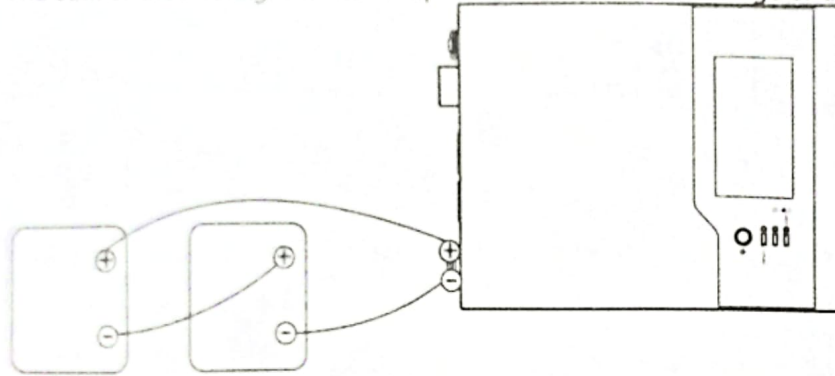

Fig 3

3) **Multiple batteries in parallel connection(Refer to Fig. 4):** Each battery's voltage must be equal to the Nominal DC Voltage of the unit.

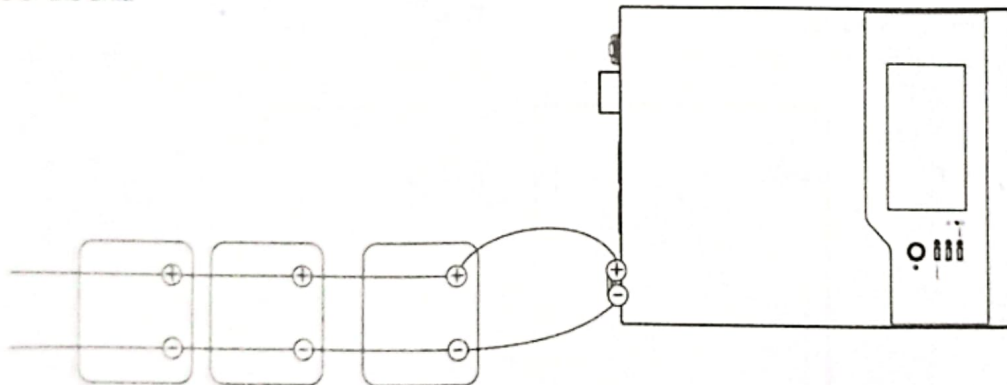

Fig 4

Step 4- Make sure to connect the polarity of battery side and the unit correctly.

Positive pole (Red) of battery to the positive terminal (+) of the unit.

Negative pole (Black) of battery to the negative terminal (-) of the unit.

Step 5- Take the DC breaker on.

Connect to Solar Panel

CAUTION: Before connecting to PV modules, please install **separately** a DC circuit breaker between inverter and PV modules.

WARNING! All wiring must be performed by a qualified personnel.

WARNING! It's very important for system safety and efficient operation to use appropriate cable for PV module connection. To reduce risk of injury, please use the proper recommended cable size as below.

Typical Amperage	Gauge	Torque Value	Conductor cross-section (mm ²)
50A	8 AWG	1.6 Nm	8.3

Step 1- Connect one cable to the positive (+) pole of solar panel and solar charger positive (+) terminal.

Step 2- Connect the other cable to the negative (-) pole of solar panel and solar charger negative (-) terminal.

Step 3- Before connecting photovoltaic solar panels, a matching circuit breaker must be connected in series. The maximum value for PV Isc is 50A.

PV Module Selection:

When selecting proper PV modules, please be sure to consider below requirements first:

1. Open circuit Voltage (Voc) of PV modules not exceeds max. PV array open circuit voltage of inverter.

INVERTER MODEL	Porsche OMP -14	Porsche OMP -24
Charging Current (MPPT)	50Amp	
System DC Voltage	12Vdc	24Vdc
Operating Voltage Range	15~80Vdc	30~80Vdc
Max. PV Array Open Circuit Voltage	100Vdc	

2. Max. Power Voltage (Vmpp) of PV modules should be close to best Vmp of inverter to get best performance. If one PV module cannot meet this requirement, it's necessary to have several PV modules in series connection. Refer to below table.

Model	Best Vmp range
Porsche OMP -14	15V~18V
Porsche OMP -24	30V~32V

Note: * Vmp: panel max power point voltage.

The PV charging efficiency is maximized while PV system voltage is close to Best Vmp range.

Maximum PV module numbers in Series: V_{mpp} of PV module * X pcs \approx Best Vmp of Inverter

PV module numbers in Parallel: Total PV module numbers / Maximum PV module numbers in series

Total PV module numbers = Max. Charging power of inverter / Pmax of PV module / 0.8 (MPPT conversion rate)

Take Porsche OMP -14 inverter as an example to select proper PV modules. After considering Voc of PV module not exceeds 100Vdc and max. Vmpp of PV module close to 15Vdc or within 15Vdc ~ 18Vdc, we can choose PV module with below specification.

Maximum Power (Pmax)	150W	Max. PV module numbers in series $1 \rightarrow 18.1 \times 1 \approx 15 \sim 18$
Max. Power Voltage Vmpp(V)	18.1V	
Max. Power Current Impp(A)	8.31A	Total PV module numbers $6 \rightarrow (685W \div 150W) / 0.8 = 5.7$ PV module numbers in parallel $6 / 1 = 6$
Open Circuit Voltage Voc(V)	22.4V	
Short Circuit Current Isc(A)	8.66A	

Maximum PV module numbers in Series: 1

PV module numbers in Parallel: 6

Total PV module numbers: 6

Take Porsche OMP -24 inverter as an example to select proper PV module. After considering Voc of PV module not exceed 100Vdc and max. Vmpp of PV module close to 30Vdc ~ 32Vdc, we can choose PV module with below specification.

Maximum Power (Pmax)	260W	Max. PV module numbers in series $1 \rightarrow 30.9 \times 1 \approx 30 \sim 32$
Max. Power Voltage Vmpp(V)	30.9V	
Max. Power Current Impp(A)	8.42A	Total PV module numbers $7 \rightarrow (1370W \div 260W) / 0.8 = 6.6$ PV module numbers in parallel $7 / 1 = 7$
Open Circuit Voltage Voc(V)	37.7V	
Short Circuit Current Isc(A)	8.89A	

Maximum PV module numbers in Series: 1

PV module numbers in Parallel: 7

Total PV module numbers: 7



CAUTION: Please strictly follow installation procedure when you want to connect PV or DC terminals. Don't touch the DC terminals and the PV terminals by hand. Failure to follow these

instructions can result in serious electrical shock.

Connect to the Load

Remove insulation sleeve 10mm for three conductors. And shorten phase L and neutral conductor N 3 mm. Insert AC output wires according to polarities indicated on terminal block and tighten the terminal screws. Be sure to connect PE protective conductor (⊕) first.

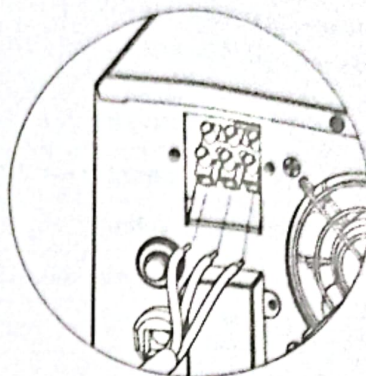

- ⊕ → Ground (yellow-green)
- L → LINE (brown or black)
- N → Neutral (blue)

5. Operation

Power On/Off

Once the inverter has been properly installed, press the power switch to turn on the unit. The unit will work automatically in line mode or inverter mode according to input utility power's status. When press the power switch again, the unit will be turned off.

LED Indicators, Function Keys & Audible Alarms

There are three indicators in the front panel of the unit.

LED Indicator		Messages	
● AC ● INV	Green	Solid On	Output is available in bypass mode
		Flashing	Output is powered by battery in inverter mode
● CHG	Green	Solid On	Battery is charging by SCC
		Flashing	Battery is not charging by SCC while SCC power on
FAULT	Red	Solid On	Fault mode
		Flashing	battery low or overload warning

Function Keys

Function Key		Description
ESC	ESC	To exit setting mode
SELECT ENTER	SELECT	To go to next selection
SET	ENTER	To confirm the selection in setting mode or enter setting mode

Audible Alarms

Buzzer Audible Alarm	Messages
Inverter Mode (Low-battery Voltage)	Buzzing every 1 seconds
110% overload warning	Buzzing every 0.5 second
Overcharge	Buzzing continuously
Fault mode	Buzzing continuously

LCD Display

Display	Function
Input source information	
AC	Indicates the AC input
PV	Indicates the PV input
INPUTBATTEMP 88.8 V Hz A V	Indicates input voltage, input frequency, PV voltage, charging current, battery voltage,
Configuration Program and Fault Information	
88 0	Indicates the setting programs.
88 ⚠	Indicates the warning and fault codes. Warning: 88 ⚠ Flashing with warning code Fault: 88 🔴 Lighting with fault code

Output Information



Indicates the output voltage, output frequency, load percent, load in VA, load in Watt, main board firmware version and SCC firmware version

Battery Information



Indicates the Battery level by 0-24%, 25-49%, 50-74% and 75-100% in battery mode, charging status in line mode.

In AC mode, it will present battery charging status.

Status	Battery voltage	LCD Display
Constant Current mode / Constant Voltage mode	< 11Vdc/pcs	4 bars will flash in turns.
	11Vdc ~ 11.5Vdc/pcs	Bottom bar will be on and the other three bars will flash in turns.
	11.5Vdc ~ 12.5Vdc/pcs	Bottom two bars will be on and the other two bars will flash in turns.
	> 12.5Vdc/pcs	Bottom three bars will be on and the top bar will flash.
Floating mode. Batteries are fully charged.		4 bars will be on.

In battery mode, it will present battery capacity.

Battery Voltage	LCD Display
< 11Vdc/pcs	
11.0Vdc ~ 11.5Vdc/pcs	
11.5Vdc ~ 12.5Vdc/pcs	
> 12.5Vdc/pcs	

Load Information

	Indicates overload.			
	Indicates the load level by 0-24%, 25-49%, 50-74%, and 75-100%.			
	0%~24%	25%~49%	50%~74%	75%~100%

Mode operation information







	Indicates unit connects to the mains.
	Indicates unit connects to the PV panel
	Indicates load is supplied by utility power.
	Indicates the utility charger circuit is working.
	Indicates the DC/AC inverter circuit is working.



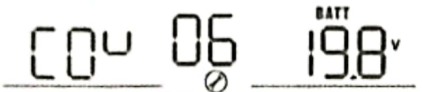
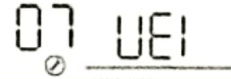
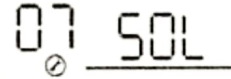
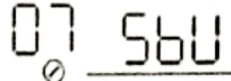

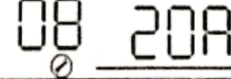

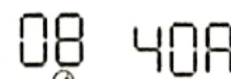
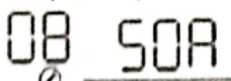
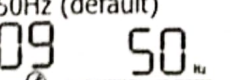
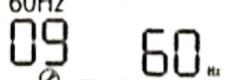

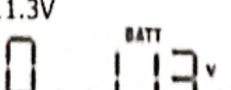
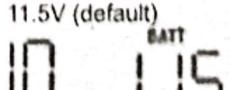
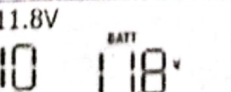
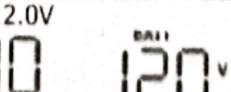
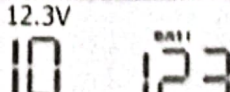

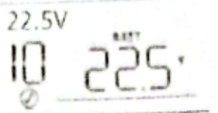
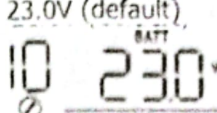
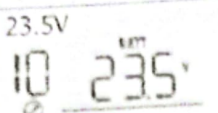

LCD Setting

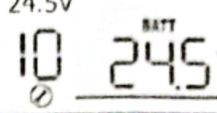

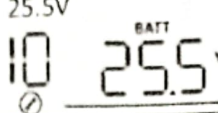
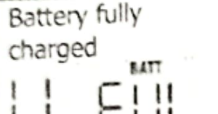
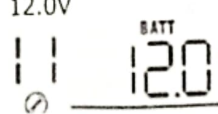
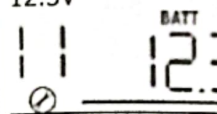
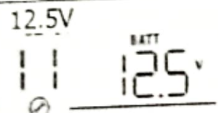
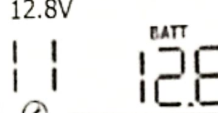
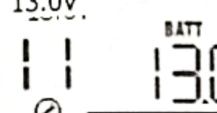
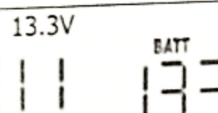
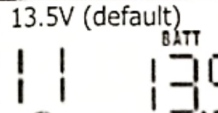
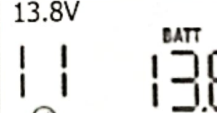
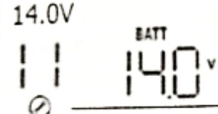
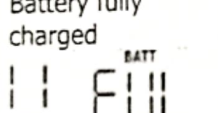
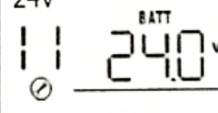
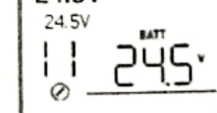
After pressing and holding ENTER button for 3 seconds, the unit will enter setting mode. Press "SCROLL" button to select setting programs. And then, press "ENTER" button to confirm the selection or ESC button to exit.

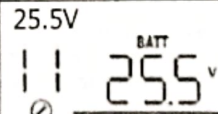
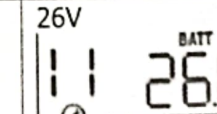
Setting Programs

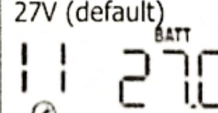
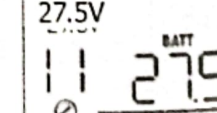
Program	Description	Selectable option
00	Exit setting mode	Escape 00 ESC
01	AC input voltage range	Wide (default) 01 uDE If selected, acceptable AC input voltage range will be within 90-280VAC.
		Narrow 01 nFu If selected, acceptable AC input voltage range will be within 170-280VAC.
02	Battery type	AGM(Default) Flooded 02 AGn 02 FLd
		User-defined 02 USE
03	Max AC charging current	20A(default) Ue1 03 20A
		10A Ue1 03 10A
04	Bulk charging (C.V voltage)voltage	Porsche OMP -14 model default setting: 14.1V Cu 04 14.1 ^{BATT}
		Porsche OMP -24 model default setting: 28.2V Cu 04 28.2 ^{BATT}
		If self-defined is selected in program 02, this program can be set up. Setting range is from 13.0V to 14.6V for Porsche OMP -14 model and increment of each click is 0.1V. Setting range is from 26.0V to 29.2V for Porsche OMP -24 model and increment of each click is 0.2V.
05	Floating charging voltage	Porsche OMP -14 model default setting: 13.5V FLu 05 13.5 ^{BATT}
		Porsche OMP -24 model default setting: 27.0V FLu 05 27.0 ^{BATT}
		If self-defined is selected in program 02, this program can be set up. Setting range is from 13.0V to 14.6V for Porsche OMP -14 model and increment of each click is 0.1V. Setting range is from 26.0V to 29.2V for Porsche OMP -24 model and increment of each click is 0.2V.



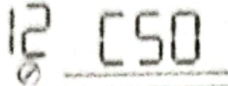
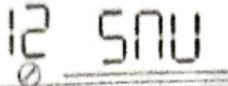

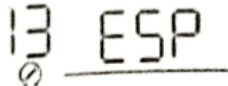
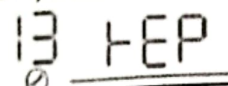
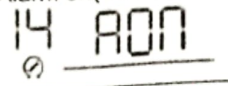
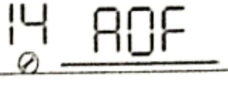



06	Low DC cut-off voltage	Porsche OMP -14 default setting: 9.9V 		
		Porsche OMP -24 default setting: 19.8V 		
		Setting range is from 9.9V to 12.0V for Porsche OMP -14 model and increment of each click is 0.1V Setting range is from 19.8V to 24.0V for Porsche OMP -24 model and increment of each click is 0.2V. Low DC cut-off voltage will be fixed to setting value no matter what percentage of load is connected.		
07	Output source priority: To configure load power source priority	Utility first (default) 	Utility will provide power to the loads as first priority. Solar and battery energy will provide power to the loads only when utility power is not available.	
		Solar first 	Solar energy provides power to the loads as first priority. If solar energy is not sufficient to power all connected loads, battery energy will supply power the loads at the same time. Utility provides power to the loads only when any one condition happens: - Solar energy is not available - Battery voltage drops to low-level warning voltage or the setting point in program 10.	
		SBU priority 	Solar energy provides power to the loads as first priority. If solar energy is not sufficient to power all connected loads, battery energy will supply power to the loads at the same time. Utility provides power to the loads only when battery voltage drops to either low-level warning voltage or the setting point in program 10.	
08	Maximum charging current: To configure total charging current for solar and utility chargers. (Max. charging current = utility charging current + solar charging current)	10A 	20A 	
		30A 	40A 	
		50A (default) 		
09	Output frequency	50Hz (default) 	60Hz 	
10	Setting voltage point back to utility source when selecting "SBU priority" or "Solar first" in program 07.	Available options in Porsche OMP -14 model:		
		11.0V 	11.3V 	11.5V (default) 
		11.8V 	12.0V 	12.3V 

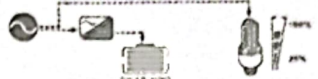

		12.5V 	12.8V 
		Available options in Porsche OMP -24 model:	
		22.0V 	22.5V 
			23.0V (default) 
		23.5V 	24.0V 
			24.5V 
		25.0V 	25.5V 
11	Setting voltage point back to battery mode when selecting "SBU priority" or "Solar first" in program 07.	Available options in Porsche OMP -14 model:	
		Battery fully charged 	12.0V 
			12.3V 
		12.5V 	12.8V 
			13.0V 
		13.3V 	13.5V (default) 
			13.8V 
		14.0V 	
		Available options in Porsche OMP -24 model:	
		Battery fully charged 	24V 
			24.5V 
		25V 	25.5V 
			26V 
		26.5V 	27V (default) 
			27.5V 
		28V 	
12	Charger source priority: To configure charger source priority	If this inverter/charger is working in Line, Standby or Fault mode, charger source can be programmed as below:	
		Utility first 	Utility will charge battery as first priority. Solar energy will charge battery only when utility power is not available.

		Solar first 	Solar energy will charge battery as first priority. Utility will charge battery only when solar energy is not available.
		Solar and utility 	Solar energy and utility will charge battery at the same time.
		Only Solar 	Solar energy will be the only charger source no matter utility is available or not.
		If this inverter/charger is working in Battery mode, only solar energy can charge battery. Solar energy will charge battery if it's available and sufficient.	
13	Auto return to default display screen	Return to default display screen (default) 	If selected, no matter how users switch display screen, it will automatically return to default display screen (Input voltage /output voltage) after no button is pressed for 1 minute.
		Stay at latest screen 	If selected, the display screen will stay at latest screen user finally switches.
14	Beeps while primary source is interrupted	Alarm on(default) 	Alarm off 







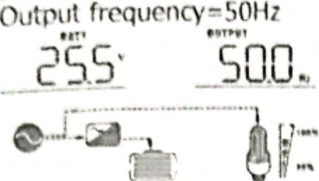

Display Setting

The LCD display information will be switched in turns by pressing "SCROLL" key. The selectable information is switched as below order: input voltage, input frequency, PV voltage, charging current, battery voltage, output voltage, output frequency, load percentage, load in VA, load in Watt, load in VA, load in Watt, DC discharging current, main CPU Version and second CPU Version.

Selectable information	LCD display	Selectable information	LCD display
Input voltage/Output voltage (Default Display Screen)	<p>Input Voltage=230V, output voltage=230V</p> <p>INPUT 230^v OUTPUT 230^v</p> 	Load percentage	<p>Load percent=70%</p> <p>BATT 25.5^v LOAD 70%</p> 
Input frequency	<p>Input frequency=50Hz</p> <p>INPUT 50.0^{Hz} OUTPUT 230^v</p> 	Load in VA	<p>When connected load is lower than 1kVA, load in VA will present xxxVA like below chart.</p> <p>BATT 25.5^v LOAD 350^{VA}</p>  <p>When load is larger than 1kVA ($\geq 1\text{kVA}$), load in VA will present x.xkVA like below chart.</p> <p>BATT 25.5^v LOAD 150^{VA}</p> 
PV voltage	<p>PV voltage=30V</p> <p>INPUT 30^v OUTPUT 230^v</p> 	Load in Watt	<p>When load is lower than 1kW, load in W will present xxxW like below chart.</p> <p>BATT 25.5^v LOAD 270^W</p>  <p>When load is larger than 1kW ($\geq 1\text{kW}$), load in W will present x.xkW like below chart.</p> <p>BATT 25.5^v LOAD 120^W</p> 
Charging current (if PV normal)	<p>Charging current=50A</p> <p>BATT 50^A OUTPUT 230^v</p> 	Main CPU version checking	<p>Main CPU version 00001.01</p> <p>U 1 0 1 0 1</p> 

Battery voltage	Battery voltage=25.5V 	Secondary CPU version checking	Secondary CPU version 00003.03 
Output frequency	Output frequency=50Hz 		

Operating Mode Description

Operation mode	Description	LCD display
Standby mode Note: *Standby mode: The inverter is not turned on yet but at this time, the inverter can charge battery with AC bypass output.	Utility input bypass to output, charger available, LCD backlight is off	Charging by utility and PV energy. 
		Charging by utility. 
		Charging by PV energy. 
Line Mode	The unit will provide output power from the mains. It will also charge the battery at line mode.	Charging by utility and PV energy. 
		Charging by PV energy. 
		Charging by utility. 
Battery Mode	The unit will provide output power from battery and PV power.	Power from battery and PV energy. 
		Power from battery only. 

Fault Reference Code

Fault Code	Fault Event	Icon on	Fault Code	Fault Event	Icon on
00	Output short circuit		05	Fan locked	
01	Over load time out		06	Over temperature	
03	Output voltage too high		08	Over charge	

Warning Indicator

Warning Code	Warning Event	Icon flashing
01	Over load	
02	Battery low	

6. Trouble Shooting

Use the table below to solve minor problems.

Problem	LCD/LED/Buzzer	Explanation / Possible cause	What to do
When power fails, the backup time is shorten.	Battery low alarm issue quickly.	Battery voltage is too low.	Charge the unit at least 8 hours.
		Battery capacity is not full even after charge the unit for at least 8 hours.	Check the date code of the battery. If the batteries are too old, replace the batteries.
Mains exist but the unit works in battery mode.	Input voltage is displayed as 0 on the LCD and green LED is flashing.	Input protector is tripped	Check if AC breaker is tripped and AC wiring is connected well.
	Green LED is flashing.	Insufficient quality of AC power. (Shore or Generator)	1. Check if AC wires are too thin and/or too long. 2. Check if generator (if applied) is working well or if input voltage range setting is correct. (Narrow→Wide)
	Green LED is flashing.	Set "Solar First" as the priority of output source.	Change output source priority to Utility first.
No LED display on the front panel when the utility power is normal.	No LED display.	Battery is not connected well.	Check the external battery cable and terminal. Make sure all the battery connections to the unit are all correct.
		Battery defect.	Replace the batteries.
Buzzer beeps continuously and red LED is on.	Fault code 00	Output short circuited.	Check if wiring is connected well and remove abnormal load.
	Fault code 01	Overload error. The inverter is overload 110% and time is up.	Reduce the connected load by switching off some equipment.
	Fault code 03	Output voltage too high	Return to repair center.
	Fault code 05	Fan fault	Replace the fan.
	Fault code 06	Internal temperature of inverter component is over 100°C.	Check whether the air flow of the unit is blocked or whether the ambient temperature is too high.
	Fault code 08	Battery is over-charged.	Return to repair center.
The battery voltage is too high.		Check if spec and quantity of batteries are meet requirements.	

If there is any abnormal situations occur, which doesn't list above, please call the service people immediately for professional examine.

7. Specifications

MODEL	Porsche OMP -14	Porsche OMP -24
CAPACITY	1400VA/900W	2400VA/1600W
INPUT		
Voltage	220-240 VAC	
Voltage Range	90-280 VAC	
Nominal Operating Frequency	50/60Hz	
Maximum Input Current	10A	13A
OUTPUT		
Nominal Output Voltage	220-240 VAC	
Voltage Regulation (Batt. Mode)	+/-10%	
Output Frequency Range	50/60Hz	
Nominal Output Current	5.2A	10.4A
Inrush Current	10A	13A
Maximum Output Fault Current	6.9A	13.6A
Transfer Time	20 ms typical	
Waveform	Simulated Sine Wave	
BATTERY		
Battery Voltage	12 VDC	24 VDC
Maximum Battery Discharging Current	76A	76A
Floating Charge Voltage	13.7 VDC \pm 0.5 VDC	27.4 VDC \pm 1 VDC
Maximum AC Charging Current	10 A or 20 A	10 A or 20 A
SOLAR CHARGER		
Solar Charger Type	MPPT	
Maximum PV Array Open Circuit Voltage	100 VDC	
MPP Range @ Operating Voltage	15 ~ 80 VDC	30 ~ 80 VDC
Maximum Solar Charging Current	50 A	50 A
Maximum Charging Current	50 A	50 A
PHYSICAL		
Dimension (DxWxH) mm	272 x 212 x 127	
Net Weight (kgs)	4.5	4.8
Protective Class	I	
Ingress Protection Rating	IP20	
ENVIRONMENT		
Humidity	0 ~ 90% RH (No condensing)	
Operating Temperature	0 to 55°C	
Altitude	0 ~ 1000 m	

